

# Thin Film FH-301/500 Series

# Hall Sensors

InAs Thin Film, General Purpose, Transverse

## Description

FH-301 & FH-500 Series Hall sensors are miniature solid-state Hall effect magnetic field sensing devices. The FH-500 series uses a lead strip which is composed of printed circuit leads encased in DuPont's Kapton and terminating in contacts on .075" centers. This flexible and tough lead strip can be made in a variety of configurations. The model FH-301 has conventional wire leads.

## Mechanical Specifications

Leads: AWG 34 copper with polyurethane insulation (FH-301).

## Electrical Specifications

a. Polarity: With field direction (+B) as shown and  $I_c$  entering the  $I_c$  (+) terminal, the positive Hall voltage will appear at the  $V_H$  (+) terminal.

b. Note: Unless otherwise specified, all specifications apply at nominal control current with  $T = 25^\circ\text{C}$ . Heat sinking can enhance performance in several respects.

## Models

FH-301-020	Low Currentent
FH-520	Lowest Cost
FH-301-040	Leaded
FH-540	Low Current On-Lead Strip
FH-301-060	Higher Sensitivity
FH-560	Higher Sensitivity
FH-301L	High Linearity
FH-500L	High Linearity



Hall Sensors

SPECIFICATIONS	UNITS	FH-301-020 /FH-520	FH-301-040/ FH-540	FH-301-060/FH-560
Input resistance, $R_{in}$	ohms	20-40	40-80	80-160
Output resistance, $R_{out}$	ohms	28-120	56-240	150-480
Magnetic sensitivity, $V_H$ (1)	mV/kg	10 min.	12 min.	12 min.
Max. resistive residual voltage, $V_M @ B=0$ (2)	$\pm$ mV	2	4	6
Max. control current @ 25°C, static air	mA	50	30	25
Nominal control current, $I_{cn}$	mA	25	15	10
Mean temperature coefficient of $V_H$ (-20°C to +80°C) (2)	%/°C	-0.1max.	-0.1max.	-0.1max.
Mean temperature coefficient of resistance (-20°C to +80°C) (2)	%/°C	+0.1max.	+0.1max.	+0.1max.
Temperature dependence of resistive residual voltage (-20°C to +80°C) (1)	$\pm$ $\mu$ V/°C	10 max.	10 max.	10 max.
Operating temperature range	°C	-55 to +100	-55 to +100	-55 to +100
Storage temperature range	°C	-55 to +120	-55 to +120	-55 to +120

### Notes

- (1)  $I_c = I_{cn}$
- (2)  $I_c = 10$  mA
- (3) maximum linearity error (-20 to +20kg) =  $\pm 1\%$  of RDG



**SYPRIS**  
TEST & MEASUREMENT

6120 Hanging Moss Road • Orlando, Florida 32807 • [www.fwbell.com](http://www.fwbell.com)  
Phone (407) 678-6900 • Fax (407) 677-5765 • Toll Free (800) 778-6117



Rev. date 05/2009

# Mechanical Dimensions

All dimensions are in inches

## Model FH-301/FH-500

Hall Sensors

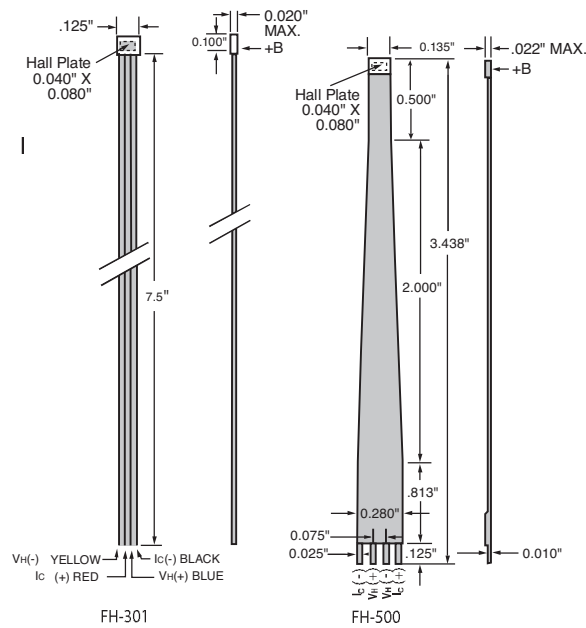

NOTE: All tolerances unless specified are ± 0.010"

Note: Due to continuous process improvement, all specifications are subject to change without notice.



**SYPRIS**  
TEST & MEASUREMENT

6120 Hanging Moss Road • Orlando, Florida 32807 • [www.fwbell.com](http://www.fwbell.com)  
Phone (407) 678-6900 • Fax (407) 677-5765 • Toll Free (800) 778-6117

Rev. date 05/2009